

## Application

The Uni-P Pro 120X dehumidifier is able to extract 120 pints of water at a standard rating condition of 80°F/60%RH in a space, not more than 3,300 sq.ft.

This unit will only use up 8.3amps/115V while controlling the humidity levels. It is built with high capacity, high energy use efficiency and is environmentally friendly.

The Uni-P Pro 120X dehumidifier is built for use in a mid-size commercial set up, however since it is built small and compact,

this unit can be easily moved into any space that requires dehumidification using already fitted heavy duty carrier handles.

This design also allows the unit to easily hang overhead.

The Uni-P Pro 120X dehumidifier is one of most purchased commercial space dehumidifiers for its quiet operation abilities. This unit will produce sounds below 60DBA, hence your workplace will remain comfortable for you, your employees and most importantly your customers.



## UNI-P Pro 120X Commercial Dehumidifier

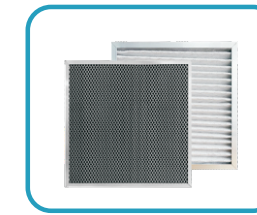

MERV-1 filter  
MERV-10 filter

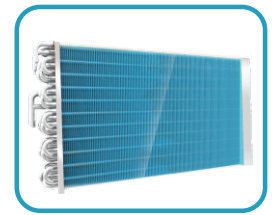

Rare earth alloy tube evaporator

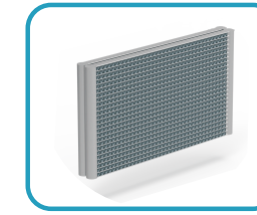

Microchannel coldan heat exchanger



Condensate Pump

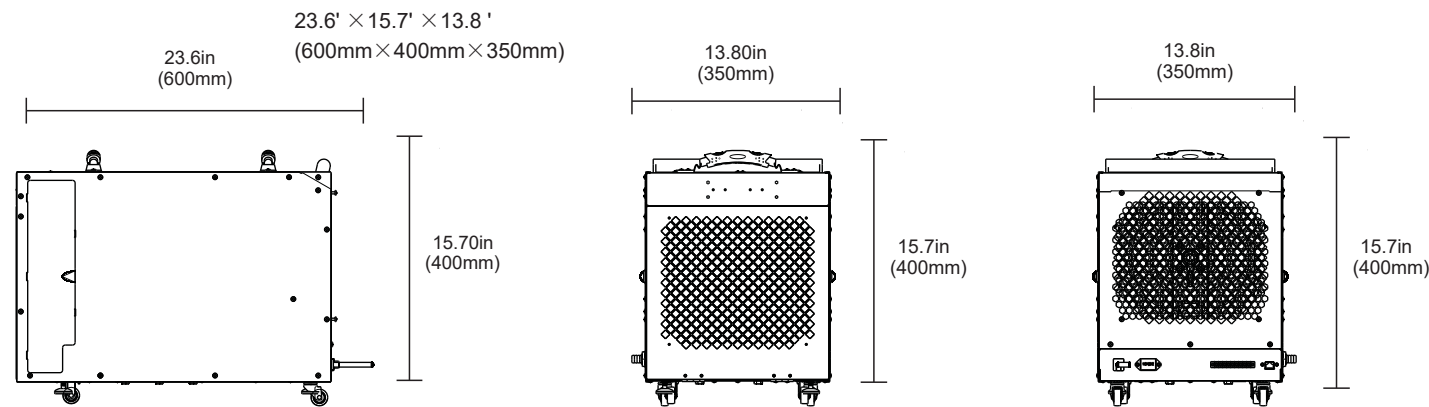

## Performance

- **Air filtration** - The Uni-P Pro 120X dehumidifier is fitted with MERV - 8 filters that are able to trap even the smallest mold spores, dust particles and any other allergens in the air. The Uni-P Pro 120X dehumidifier will improve the quality of your indoor air hence reducing the number of respiratory problems and allergies in your employees.

Note: to achieve the desired dehumidification results with The Uni-P Pro 120X dehumidifier, space must be free of water intrusion or excessive fresh outdoor air infiltration. All water intrusion and air infiltration problems should be fixed before installation.

## Features

- ✓ CETL
- ✓ Compressor Type Rotary
- ✓ More Thorough, And More Quick
- ✓ Ducting options
- ✓ Condensate Pump
- ✓ Easy handling
- ✓ Water Full protection
- ✓ Environmental R410A Refrigerant
- ✓ Automatic humidistat control
- ✓ Memory Starting
- ✓ Washable Air Filter
- ✓ Wheels
- ✓ Low Temperature
- ✓ Cable / Hose Wrap
- ✓ Quick connection to Cable/Hose

## Specifications

<b>Power</b> 115V/60HZ	<b>Current Draw</b> 7.8 Amps
<b>Size For</b> Up to 3300Sq.FT	<b>Capacity115V(80°F-60%)</b> 120Pints
<b>Filter</b> MERV-1-Filter / MERV-10 Filter	<b>Wheel</b> Portable Wheel
<b>Compressor type</b> Rotaly	<b>COP(115v/60Hz)</b> 2.7L/Kwh(115v/60Hz),3.0L/Kwh(220v/50Hz)
<b>Sound Pressure Level</b> <60DBA	<b>Power Cord</b> 110-120 VAC, Ground
<b>Refrigerant</b> R410a	<b>Weight</b> 88lbs
<b>Display type</b> Digital	<b>Dim(D*H*W)</b> 23.8' × 14.7' × 17.9' (605mm × 375mm × 455mm)
<b>Draining</b> Condensate Pump	<b>Loading quantity</b> 20":132Sets/40":292Sets/40"HQ :365Sets
<b>CFM(air flow)</b> 290 CFM	<b>Ideal Functioning Humidity Range</b> 36~90%
	<b>Functioning Temperature Range</b> 33.8°F Min - 104°F Max

Get the **Uni-P Pro 120X dehumidifier** today and experience the change!